

Instructions Manual

Tektronix

**TAS 200 Series
Oscilloscopes**

070-9855-01

Table of Contents

| | |
|--|-----------|
| TAS 200 Series Oscilloscopes | 1 |
| TAS 200 Series Specifications | 3 |
| TAS 200 Series Performance Verification | 7 |
| Test Equipment | 8 |
| Set Up | 9 |
| Vertical Check | 10 |
| Horizontal Check | 15 |
| Trigger Check | 17 |
| Cursor Check | 19 |
| TAS 200 Series Adjustment Procedures | 21 |
| List of Adjustments | 21 |
| Test Equipment | 23 |
| Preparation for Adjustment | 24 |
| Power Supply Adjustments | 27 |
| Vertical Adjustments | 30 |
| Horizontal Adjustments | 37 |
| Trigger Adjustments | 40 |
| Probe Compensation | 42 |
| Cursors and Readout Adjustments | 43 |

TAS 200 Series Oscilloscopes

The Tektronix TAS 220 and TAS 250 oscilloscopes are dual-channel products with frequency bandwidths of DC to 20 MHz and DC to 50 MHz respectively. Both oscilloscopes feature a maximum sensitivity of 1 mV/division and a maximum sweep speed of 10 ns/division.

In addition, the TAS 200 series oscilloscopes offer the following features:

- High beam transmission and high intensity CRT displays for clear waveforms at high sweep speeds.
- High stability low-drift temperature compensation circuits to reduce baseline and DC balance drift.
- Trigger feature, Set to 50% that eliminates triggering adjustments when displaying regular, video, and large duty-cycle-ratio signals.
- Synchronization separator and trigger circuitry that permits the display of TV signals. (You can automatically select vertical and horizontal signals with the SEC/DIV control.)
- Automatic focus (following an initial intensity adjustment).

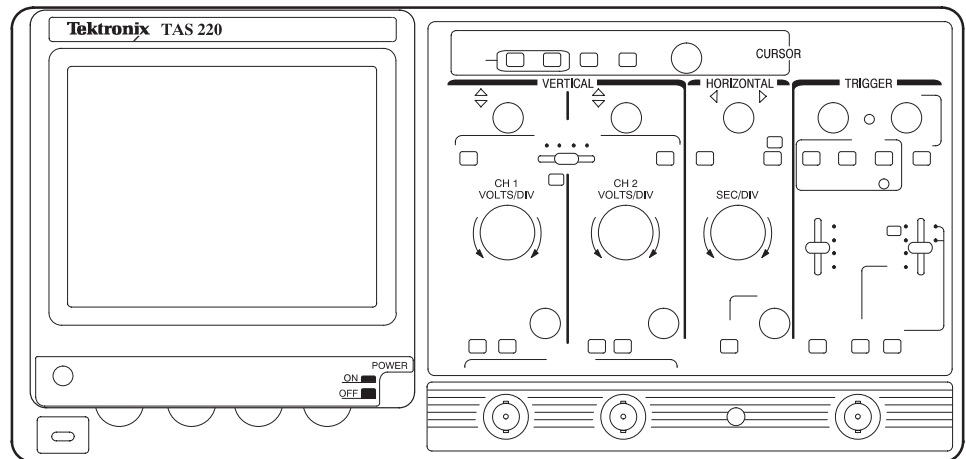

Figure 1: TAS 220 oscilloscope

TAS 200 Series Specifications

The characteristics listed in this section apply under the following conditions:

- The instrument operates in a 0° to 40° C ambient environment unless otherwise noted.
- The instrument warms up for at least 20 minutes.
- The instrument is adjusted at an ambient temperature between 20° and 30° C.

NOTE. All specifications are warranted unless marked “typical.” Typical characteristics are not guaranteed but are provided for the convenience of the user.

NOTE. Input limits apply to signals with frequencies less than 1 kHz.

Table 1: Vertical deflection characteristics

| Characteristic | TAS 220 description | TAS 250 description |
|---------------------------------------|---|--|
| Frequency Bandwidth (-3 dB) | DC to 20 MHz (5 mV/div to 5 V/div at 5° to 35° C) | DC to 50 MHz (at 0° to 10° C and 35 to 40° C) |
| | DC to 15 MHz | DC to 40 MHz (at 0° to 5° C and 35° to 40° C) |
| | DC to 10 MHz (1mV/div to 2 mV/div) | DC to 15 MHz |
| Vertical Gain (15° to 35° C) | 5 mV/div to 5 V/div: ±3% | |
| | 1 mV/div to 2 mV/div: ±5% | |
| Variable Gain (Typical) | To 1/2.5 or less of the readout indicated value. | |
| Common Mode Rejection Ratio (Typical) | 50 kHz: >50:1 | |
| | 10 MHz: >10:1 | |
| Input Impedance (Typical) | 1 MΩ, 30 pF | |
| Vertical Linearity (Typical) | ±0.1 division or less of amplitude change when a waveform of two divisions at graticule center is moved vertically. | |
| DC Balance Shift (Typical) | 5 mV/div to 5 V/div: ±0.5 divisions | |
| | 1 mV/div to 2 mV/div: ±2.0 divisions | |

Table 1: Vertical deflection characteristics (cont.)

| Characteristic | TAS 220 description | TAS 250 description |
|---|--|---------------------|
| Chopping Repetition Frequency (Typical) | 250 kHz | |
| Maximum Input Voltage | 400 V (DC + peak AC) | |
| Channel Isolation (Typical) | 50 kHz: 1000:1 | |
| | 10 MHz: 100:1 | |
| | 20 MHz: 30:1 | 50 MHz: 30:1 |
| CH 1 Signal Output (Typical) | 100 mV/div open circuit | |
| | 50 mV/div into 50 Ω | |
| CH 2 INV Balance (Typical) | ≤ 1 division balanced point variation | |

Table 2: Horizontal characteristics TAS 200 series

| Characteristic | Description |
|-------------------------------|--|
| Standard Sweep Time Accuracy | 15° to 35° C: $\pm 3\%$ |
| | 0° to 15° C and 35° to 40° C: $\pm 4\%$ |
| Magnified Sweep Time Accuracy | 1 $\mu\text{s}/\text{div}$ to 0.5 sec/div: $\pm 5\%$ |
| | 0.1 to 0.5 $\mu\text{s}/\text{div}$: $\pm 8\%$ |
| Sweep Linearity | |
| Standard | $\pm 3\%$ |
| X10 MAG | $\pm 5\%$ |
| X10 MAG | 0.1 to 0.5 $\mu\text{s}/\text{div}$: $\pm 8\%$ |

Table 3: Readout characteristics TAS 200 series

| Characteristic | Description |
|--------------------|--|
| Readout Resolution | 1/25 div |
| Readout Accuracy | $\pm 3\% + 1/25$ div |
| Readout Modes | ΔV , ΔT , $1/\Delta T$ |

Table 4: Trigger characteristics

| Characteristic | TAS 220 description | TAS 250 performance description |
|--|----------------------|---------------------------------|
| Sensitivity | | |
| 0.5 divisions (internal), 0.1 V (external) | DC to 5 MHz | DC to 10 MHz |
| 1.5 divisions (internal), 0.2 V (external) | 5 to 20 MHz | 10 to 50 MHz |
| 2.0 divisions (internal), 0.2 V (external) | Video | Video |
| Input Impedance (Typical) | 1 M Ω , 30 pF | |
| Maximum Input Signal | 100 V (DC + peak AC) | |

Table 5: Typical Z-Axis characteristics TAS 200 series

| Characteristic | Description |
|-----------------------|--|
| Maximum Input Voltage | 50 V (DC + peak AC) |
| Sensitivity | 3 V _{p-p} (Trace becomes brighter with negative input.) |
| Frequency Bandwidth | DC to 5 MHz |
| Input Resistance | 5 k Ω |

Table 6: Typical X-Y mode operation

| Characteristic | TAS 220 description | TAS 250 description |
|----------------------|--|-----------------------------------|
| Sensitivity | Same as CH 1 vertical axis | |
| Sensitivity Accuracy | 5 mV to 5 V/div: $\pm 4\%$ 1 to 2 mV/div: $\pm 6\%$ | |
| Frequency Bandwidth | DC to 1 MHz | DC to 2 MHz |
| X-Y Phase Difference | $\leq 3^\circ$ from DC to 50 kHz | $\leq 3^\circ$ from DC to 100 kHz |
| EXT HOR Sensitivity | 0.1 V/div | |

Table 7: Typical probe compensation signal characteristics TAS 200 series

| Characteristic | Description |
|-------------------|----------------------------|
| Waveform | Positive going square wave |
| Frequency | 1 kHz |
| Duty Ratio | 50:50 |
| Output Level | 2 V _{p-p} |
| Output Resistance | 2 k Ω |

Table 8: Environmental characteristics

| Characteristic | Description |
|------------------------------------|---|
| Temperature | |
| Operating | 0° to 40° C |
| Nonoperating | -40° to +70° C Tested to MIL-T-28800D, paragraphs 4.5.5.1.3 and 4.5.5.1.4, except in 4.5.5.1.3 steps 4 and 5 (0° C operating test) are performed ahead of step 2 (-40° C nonoperating test). Equipment shall remain off upon return to room ambient during step 6. Excessive condensation shall be removed before operating during step 7. |
| Altitude | |
| Operating | ≤4,570 meters (15,000 feet). Maximum operating temperature decreases 1° C per 300 m (1,000 feet) above 1,500 m (5,000 feet). |
| Nonoperating | ≤15,250 meters (50,000 feet) |
| Relative Humidity | |
| Operating | 30° to 40° C, 90% relative humidity +0%, -5% |
| Nonoperating | 30° to 60° C, 90% relative humidity +0%, -5% Five cycles (120 hours) referenced to MIL-T-28800D paragraph 4.5.1.2.2 for type III, class 5 instruments. Operating and nonoperating at 90%, +0%, -5% relative humidity. |
| Vibration (Operating) | 15 minutes along each of three major axes at a total displacement of 0.015 inch peak-to-peak (2.4 g at 55 Hz) with frequency varied from 10 Hz to 55 Hz to 10 Hz in one minute sweeps. Hold for 10 minutes at 55 Hz in each of three major axes. All major resonances must be above 55 Hz. |
| Shock (Operating and Nonoperating) | 30 g, half-sine, 11 ms duration, three shocks per axis each direction, for a total of 18 shocks. |
| Radiated and Conducted Emissions | Meets EN55011, class A. |
| Safety | Listed CSA C22.2 No. 231 and UL1244 |

Table 9: Typical mechanical characteristics TAS 200 series

| Characteristic | Description |
|--------------------|---|
| Dimensions | 32.7 cm × 16.2 cm × 46.3 cm (12.9 inch × 6.38 inch × 18.2 inch) |
| Weight | 7.0 kg (15.4 lbs) |
| Operating Voltages | 100 V, 120 V, 220 V, 240 V, 10% variation from selector range permitted. |
| Line Frequency | 50 or 60 Hz |
| Power Consumption | 70 VA |

TAS 200 Series Performance Verification

This section contains procedures to verify that the TAS 220 and TAS 250 oscilloscopes perform as warranted. Verify instrument performance whenever the accuracy or function of your instrument is in question. The procedures are organized into four sections: Vertical Check, Horizontal Check, Trigger Check, and Cursor Check.

The performance verification procedures provide a valid confirmation of instrument electrical characteristics and function under the following conditions:

- The instrument operates in a 20° to 30° C ambient environment.
- The oscilloscope warms up for at least 20 minutes.
- The cabinet remains installed on the oscilloscope.

The performance verification procedure should be performed annually or after every 2000 hours of operation if used infrequently.

Table 11 lists the equipment needed to do the performance verification procedures.

The TAS 200 series performance verification consists of the checks listed in Table 10.

Table 10: Performance verification checks

| |
|-------------------------------------|
| Vertical Check |
| DC Gain Accuracy |
| DC Coupled Bandwidth |
| DC Balance |
| Variable DC Balance |
| CH 2 Inverted Balance |
| Horizontal Check |
| Time Base Accuracy |
| Trigger Check (Trigger Sensitivity) |
| Cursor Check |
| ΔT Measurement Accuracy |
| ΔV Measurement Accuracy |

Test Equipment

The performance verification procedures use external traceable test equipment to directly check warranted characteristics.

Alternative test equipment must meet or exceed the intended minimum requirements. If you substitute equipment, you may need to modify the performance verification procedures.

NOTE. Before beginning the performance verification procedures, warm up the test equipment according to the manufacturer's recommendations.

Table 11: Performance verification test equipment

| Description | Minimum requirements | Example product |
|-----------------------------|--|---|
| Leveled Sine Wave Generator | 200 kHz to 250 MHz; variable amplitude from 5 mV to 4 V _{p-p} into 50 Ω | Wavetek 9100 Universal Calibration System with Oscilloscope Calibration Module (Option 250) |
| Time Mark Generator | Variable marker frequency from 10 ms to 10 ns; accuracy within 2 ppm | Fluke 5500A Multi-product Calibrator with Oscilloscope Calibration Option 5500A-SC |
| DC Calibration Generator | DC voltage levels from 100 mV to 10 V | |
| Digital Multimeter | 35 V, 4 A, ±0.1% Accuracy | Tektronix DMM914 Digital Multimeter |
| Termination (two required) | 50 Ω, female BNC input, male BNC output | Tektronix 011-0049-01 |
| Cable, Coaxial | 75 Ω, male-to-male BNC connectors, 36 inch length | Tektronix 012-1338-00 |
| Cable, Precision Coaxial | 50 Ω, male-to-male BNC connectors, 36 inch length | Tektronix 012-0482-00 |

Set Up

Following a 20 minute warm-up period, preset the oscilloscope to the settings listed below.

Table 12: Oscilloscope initial settings

| Control | Setting |
|----------------|----------------------------|
| INTENSITY | Visible Display |
| CURSOR ON/OFF | Off |
| VERTICAL | |
| POSITION | Midrange |
| MODE | CH1 |
| VOLTS/DIV | 10 mV |
| VARIABLE | CAL |
| GND | In |
| HORIZONTAL | |
| SEC/DIV | 10 ms |
| POSITION | Midrange |
| MAG | Off (Out) |
| X-Y | Off (Out) |
| SWEEP VARIABLE | CAL |
| TRIGGER | |
| SLOPE | Positive (push switch out) |
| LEVEL | Midrange |
| MODE | AUTO |
| SOURCE | CH 1 |
| COUPLING | DC |

Vertical Check

The following checks verify the vertical accuracy of your oscilloscope.

DC Gain Accuracy To check DC gain accuracy, perform the following steps.

1. Use the 50 Ω precision coaxial cable to connect the standard amplitude output of the DC calibration generator to the TAS 200 series oscilloscope CH 1 (CH 2) input. See Figure 2 below.

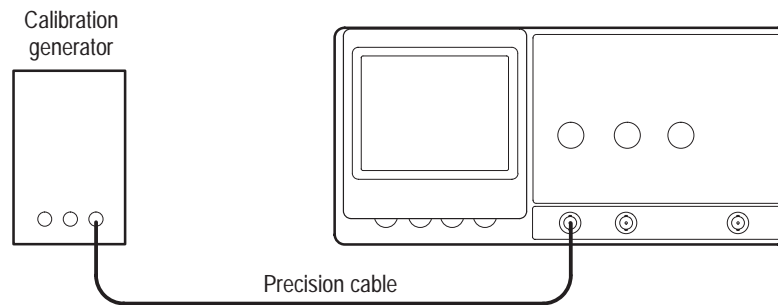

Figure 2: Gain and voltage check setup

2. Set up the oscilloscope as follows:

| | |
|-----------------------|---------------|
| VERTICAL MODE | CH1 (CH2) |
| CH 1 (CH 2) AC-DC | DC |
| CH 1 (CH 2) VOLTS/DIV | 1 mV |
| TRIGGER MODE | AUTO |
| HORIZONTAL SEC/DIV | 0.5 ms |
| CH 1 (CH 2) GND | Out (release) |

3. Set the oscilloscope CH 1 VOLTS/DIV Scale and calibration generator output to each of the values listed in Table 13; then verify that the readings on the oscilloscope remain within the limits of the Displayed Signal Accuracy.

Table 13: DC gain and displayed signal accuracy

| TAS 200 volts/div scale | Generator output | Displayed signal accuracy |
|-------------------------|------------------|---------------------------|
| 1 mV | 5 mV | 4.75 to 5.25 div |
| 2 mV | 10 mV | 4.75 to 5.25 div |
| 5 mV | 20 mV | 3.88 to 4.12 div |
| 10 mV | 50 mV | 4.85 to 5.15 div |
| 20 mV | 0.1 V | 4.85 to 5.15 div |
| 50 mV | 0.2 V | 3.88 to 4.12 div |
| 100 mV | 0.5 V | 4.85 to 5.15 div |
| 200 mV | 1 V | 4.85 to 5.15 div |
| 500 mV | 2 V | 3.88 to 4.12 div |
| 1 V | 5 V | 4.85 to 5.15 div |
| 2 V | 10 V | 4.85 to 5.15 div |
| 5 V | 20 V | 3.88 to 4.12 div |

4. Set the calibration generator output to 5 mV.
5. Return the oscilloscope CH 1 (CH 2) VOLTS/DIV control to 1 mV.
6. Rotate the oscilloscope CH 1 (CH 2) VERTICAL VARIABLE control counterclockwise off of the CAL position until the amplitude of the displayed waveform is reduced to two divisions or less.
7. Set the oscilloscope CH 1 (CH 2) VERTICAL VARIABLE control to the CAL position.
8. Disconnect the test setup from the oscilloscope.
9. Repeat steps 1 through 8 for CH 2.

DC Coupled Bandwidth

To check DC coupled bandwidth accuracy, perform the following steps.

1. Use the 50 Ω precision coaxial cable to connect the output of the leveled sine wave generator to the 50 Ω termination; then connect the 50 Ω termination to the TAS 200 series oscilloscope CH 1 (CH 2) input. See Figure 3 below.

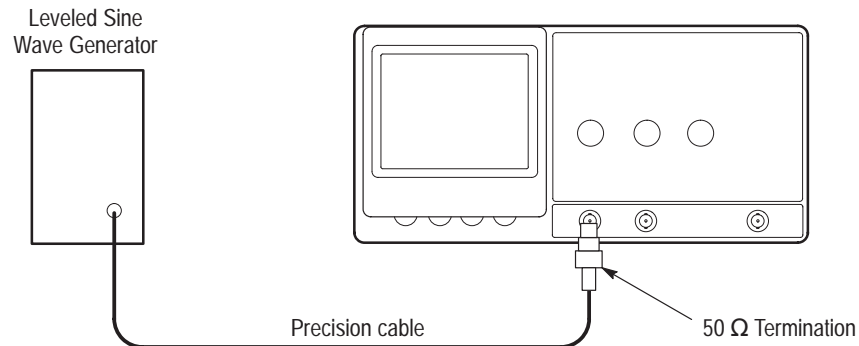

Figure 3: Bandwidth check setup

2. Set up the oscilloscope as follows:

| | |
|-----------------------|---------------|
| VERTICAL MODE | CH1 (CH2) |
| CH 1 (CH 2) AC-DC | DC |
| CH 1 (CH 2) VOLTS/DIV | 1 mV |
| HORIZONTAL SEC/DIV | 10 μ s |
| TRIGGER MODE | AUTO |
| TRIGGER COUPLING | DC |
| TRIGGER SOURCE | CH 1 (CH 2) |
| CH 1 (CH 2) GND | Out (release) |

3. To confirm the bandwidth of the input channel, perform the following substeps (a. through c.) at the settings and limits noted in Table 14.
 - a. Set the oscilloscope CH 1 (CH 2) VOLTS/DIV control as indicated.
 - b. Set the leveled sine wave generator to the specified 50 kHz reference amplitude.
 - c. Verify that the oscilloscope display amplitude remains greater than the bandwidth minimum amplitude (minimum number of divisions), while increasing the leveled sine wave generator frequency to the specified value for the CH 1 (CH 2) VOLTS/DIV setting and oscilloscope model.

NOTE. At lower VOLTS/DIV settings, you might need to set TRIGGER COUPLING to HF REJ to minimize noise or double triggering.

Table 14: DC coupled bandwidth

| Volts/Div | 50 kHz reference amplitude | Bandwidth minimum amplitude | TAS 220 bandwidth | TAS 250 bandwidth |
|-----------|----------------------------|-----------------------------|-------------------|-------------------|
| 1 mV | 6 divisions | 4.2 divisions | 10 MHz | 15 MHz |
| 2 mV | 6 divisions | 4.2 divisions | 10 MHz | 15 MHz |
| 5 mV | 6 divisions | 4.2 divisions | 20 MHz | 50 MHz |
| 10 mV | 6 divisions | 4.2 divisions | 20 MHz | 50 MHz |
| 20 mV | 6 divisions | 4.2 divisions | 20 MHz | 50 MHz |
| 50 mV | 6 divisions | 4.2 divisions | 20 MHz | 50 MHz |
| 100 mV | 6 divisions | 4.2 divisions | 20 MHz | 50 MHz |
| 200 mV | 6 divisions | 4.2 divisions | 20 MHz | 50 MHz |
| 500 mV | 6 divisions | 4.2 divisions | 20 MHz | 50 MHz |
| 1 V | 4 divisions | 2.8 divisions | 20 MHz | 50 MHz |

- Repeat steps 1 through 3 for CH 2.

DC Balance To check DC balance accuracy, perform the following steps.

- Set up the oscilloscope as follows:

| | |
|----------------------|-----------|
| VERTICAL MODE | CH1 (CH2) |
| CH 1 (CH 2) GND | In |
| CH 1 (CH 2) VARIABLE | CAL |

- Verify that the oscilloscope trace shift is less than ± 0.5 divisions when rotating the CH 1 (CH 2) VOLTS/DIV control between the 5 mV and 5 V settings.
- Verify that the oscilloscope trace shift is less than two divisions when the CH 1 (CH 2) VOLTS/DIV control is changed from the 1 mV to the 2 mV setting.
- Repeat steps 1 through 3 above for CH 2.

Variable DC Balance To check Variable DC balance accuracy, perform the following steps.

1. Set up the oscilloscope as follows:

| | |
|-----------------------|-----------|
| VERTICAL MODE | CH1 (CH2) |
| CH 1 (CH 2) AC-DC | DC |
| CH 1 (CH 2) GND | In |
| CH 1 (CH 2) VOLTS/DIV | 10 mV |

2. Verify that the oscilloscope trace shift is less than one division between the fully clockwise and the fully counterclockwise positions of the CH 1 VARIABLE control.
3. Repeat steps 1 and 2 above for CH 2.

CH 2 Inverted Balance To check CH 2 Inverted balance accuracy, perform the following steps.

1. Set up the oscilloscope as follows:

| | |
|---------------|-----|
| VERTICAL MODE | CH2 |
| CH 2 GND | In |

2. Position the oscilloscope trace on the center horizontal graticule line using the CH 2 POSITION control.
3. Verify that there is minimal trace shift ($<\pm 1$ divisions) on the TAS 200 series instrument when switching the CH 2 INVERT button in and out.
4. Set the oscilloscope CH 2 INVERT button to the out position.

Horizontal Check

The following checks verify the horizontal accuracy of your oscilloscope.

Time Base Accuracy To check time base accuracy, perform the following steps.

1. Use the 50 Ω precision coaxial cable to connect the output of the time mark generator to the 50 Ω termination; then connect the 50 Ω termination to the TAS 200 series instrument CH 1 input. See Figure 4 below.

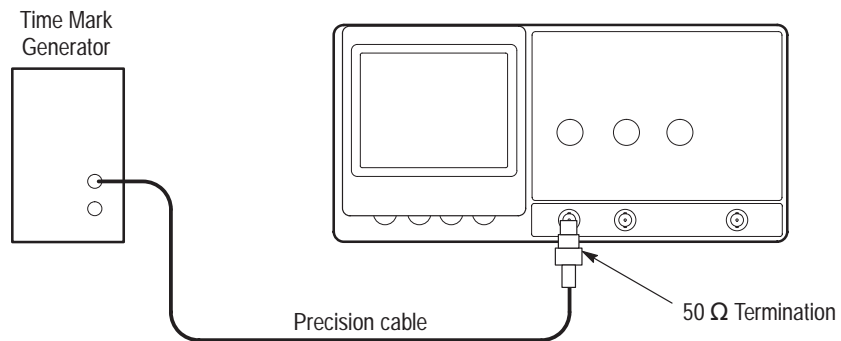

Figure 4: Timing check setup

2. Set up the oscilloscope as follows:

| | |
|--------------------|---------------|
| VERTICAL MODE | CH1 |
| CH 1 AC-DC | DC |
| CH 1 VOLTS/DIV | 0.5 V |
| CH 1 GND | Out (release) |
| HORIZONTAL SEC/DIV | .1 μ s |
| TRIGGER MODE | AUTO |
| TRIGGER COUPLING | DC |

3. Set up the time mark generator to produce 0.1 μ s markers.
4. Center the time marks vertically on the oscilloscope display.
5. Position the rising edge of the second time mark to the second vertical graticule line of the oscilloscope display.
6. Verify that the time mark to graticule accuracy over the center eight divisions is within the limits shown for each HORIZONTAL SEC/DIV setting listed in Table 15.

Table 15: Standard time base accuracies

| HORIZONTAL SEC/DIV | Time marker setting | Time mark to graticule accuracy over center 8 divisions |
|--------------------|---------------------|---|
| .1 μ s | 0.1 μ s | ± 0.24 division |
| .2 μ s | 0.2 μ s | ± 0.24 division |
| .5 μ s | 0.5 μ s | ± 0.24 division |
| 1 μ s | 1 μ s | ± 0.24 division |
| 2 μ s | 2 μ s | ± 0.24 division |
| 5 μ s | 5 μ s | ± 0.24 division |
| 10 μ s | 10 μ s | ± 0.24 division |
| 20 μ s | 20 μ s | ± 0.24 division |
| 50 μ s | 50 μ s | ± 0.24 division |
| .1 ms | 0.1 ms | ± 0.24 division |
| .2 ms | 0.2 ms | ± 0.24 division |
| .5 ms | 0.5 ms | ± 0.24 division |
| 1 ms | 1 ms | ± 0.24 division |
| 2 ms | 2 ms | ± 0.24 division |
| 5 ms | 5 ms | ± 0.24 division |

7. Set the oscilloscope HORIZONTAL SEC/DIV control to either .5 μ s (TAS 220) or .1 μ s (TAS 250).
8. Set the oscilloscope HORIZONTAL X10 MAG push switch to the on position (in).
9. Set the time mark generator to 20 ns.
10. Position the edge of the second time mark to the second vertical graticule line of the oscilloscope display.
11. Verify that the time mark to graticule accuracy over the center eight divisions is within the limits shown for each HORIZONTAL SEC/DIV setting listed in Table 16.

Table 16: X10 MAG time base accuracy

| HORIZONTAL SEC/DIV | Time marker setting | Time mark to graticule over center 8 divisions |
|--------------------|---------------------|--|
| 10 ns | 10 ns | ± 0.64 division |
| 20 ns | 20 ns | ± 0.64 division |
| 50 ns | 50 ns | ± 0.64 division |

- Set the oscilloscope HORIZONTAL X10 MAG push switch to the off position (out).

Trigger Check

The following check verifies the trigger accuracy of your oscilloscope.

- Use the 50 Ω precision coaxial cable to connect the output of the leveled sine wave generator to the 50 Ω termination; then connect the 50 Ω termination to the TAS 200 series instrument CH 1 input. See Figure 5 below.

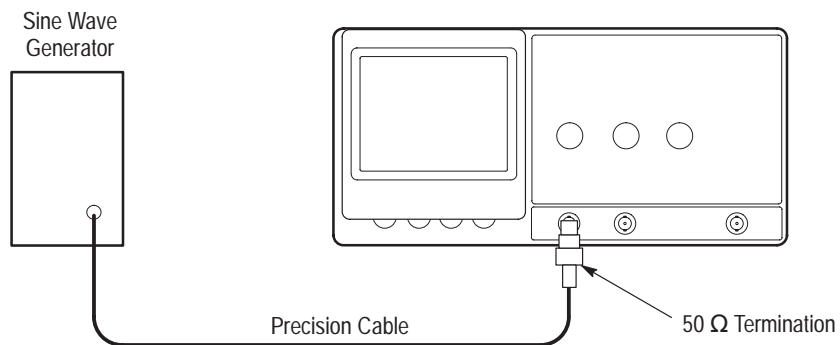

Figure 5: Trigger level check setup

- Set up the oscilloscope as follows:

| | |
|--------------------|---------------|
| VERTICAL MODE | CH1 |
| CH 1 VOLTS/DIV | 1 V |
| CH 1 AC-DC | DC |
| CH 1 GND | Out (release) |
| HORIZONTAL SEC/DIV | .5 μ s |
| TRIGGER MODE | AUTO |
| TRIGGER LEVEL | Midway |

TRIGGER COUPLING DC
 TRIGGER SET TO 50% Out (release)

3. Set the leveled sine wave generator to produce a five-division output at the low-frequency trigger level listed for your instrument. See Table 17.

Table 17: DC coupled triggering sensitivity

| | Minimum trigger waveform amplitude | TAS 220 | TAS 250 |
|------------------------|------------------------------------|---------|---------|
| Low frequency trigger | 0.5 divisions | 5 MHz | 10 MHz |
| High frequency trigger | 1.5 divisions | 20 MHz | 50 MHz |

4. Reduce the leveled sine wave generator output until the minimum trigger waveform amplitude is equal to the value listed in Table 17. If necessary, adjust the oscilloscope TRIGGER LEVEL to maintain a stable waveform during the operation.
5. Set the leveled sine wave generator for a four division output at the high frequency trigger level listed in Table 17.
6. Reduce the leveled sine wave generator output until the minimum trigger waveform amplitude is equal to the value listed in Table 17. If necessary, adjust the oscilloscope TRIGGER LEVEL to maintain a stable waveform during the operation.

Cursor Check

The following checks verify the cursor accuracy of your oscilloscope.

ΔT Measurement Accuracy

To check cursor ΔT measurement accuracy, implement the following steps.

1. Set up the oscilloscope as follows:

| | |
|--------------------|-----------|
| VERTICAL MODE | CH1 (CH2) |
| HORIZONTAL SEC/DIV | 1 ms |

2. Press and hold the oscilloscope CURSOR ON/OFF push switch to activate the cursors.
3. If not already displayed, press and hold the $\Delta V/\Delta T$ 1/ ΔT push switch until two vertical cursors appear on the display.
4. Toggle the TRACKING $\diamond - O^{(REF)}$ switch to select only the \diamond cursor.
5. Position the \diamond cursor 4 divisions to the left of the display vertical center with the CURSOR POSITION switch.
6. Toggle the TRACKING $\diamond - O^{(REF)}$ push switch to select only the O cursor.
7. Position the O cursor 4 divisions to the right of the display vertical center with the CURSOR POSITION switch.
8. Verify that the ΔT readout at the top-left corner of the display reads between 7.72 and 8.28 ms.
9. Set the VERTICAL MODE switch to CH2 and repeat steps 4 through 8 for CH 2.

ΔV Measurement Accuracy

To check cursor ΔV measurement accuracy, implement the following steps.

1. Set up the oscilloscope as follows:

| | |
|--------------------|-----------|
| VERTICAL MODE | CH1 (CH2) |
| VERTICAL VOLTS/DIV | 1 V |

2. Press and hold the oscilloscope $\Delta V/\Delta T$ 1/ ΔT push switch until two horizontal cursors appear on the display.
3. Toggle the TRACKING $\diamond - O^{(REF)}$ switch to select only the \diamond cursor.
4. Position the \diamond cursor 3 divisions above the display horizontal center with the CURSOR POSITION switch.
5. Toggle the TRACKING $\diamond - O^{(REF)}$ push switch to select only the O cursor.

6. Position the O cursor 3 divisions below the display horizontal center with the CURSOR POSITION switch.
7. Verify that the $\Delta V_{1(2)}$ readout at the top-left corner of the display, reads between 5.78 and 6.22 V.
8. Set the VERTICAL MODE switch to CH2 and repeat steps 3 through 7 for CH 2.

TAS 200 Series Adjustment Procedures

This section contains procedures to adjust TAS 220 and TAS 250 oscilloscopes. If your instrument fails a performance requirement, use these procedures to return it to factory specifications.

In this section you will find the following information:

- A list of adjustments
- A list of test equipment needed to make the adjustments
- Instructions on how to prepare instruments for adjustment
- Step-by-step adjustment procedures

The procedures in this section do not verify performance. To confirm that your oscilloscope meets factory specifications, implement the procedures in the *TAS 200 Series Performance Verification* section.

List of Adjustments

Use the adjustments listed in Table 18 to return TAS 220 and TAS 250 oscilloscopes to factory calibration.

Table 18: TAS 220 and TAS 250 adjustments

| |
|--|
| Power Supply Adjustments |
| +12 V Supply |
| Intensity |
| Focus and Astigmatism |
| Vertical Adjustments |
| DC Balance |
| Variable DC Balance |
| Channel 2 Inverted Balance and Position Center |
| ADD Mode Balance |
| Vertical Gain |
| MAG Sensitivity |
| High Frequency Compensation |
| Attenuator Compensation |
| Channel 1 Output DC Offset |

Table 18: TAS 220 and TAS 250 adjustments (cont.)

| |
|---------------------------------|
| Horizontal Adjustments |
| X10 Magnification Registration |
| Horizontal Position |
| 1 ms Timing |
| 1 μ s and .1 μ s Timing |
| X-Gain Accuracy |
| X-Axis Offset |
| Trigger Adjustments |
| Trigger DC Offset |
| Trigger Slope Balance |
| Trigger Center |
| Probe Compensation |
| Cursors and Readout Adjustments |
| Cursor Accuracy |
| Drift |

Test Equipment

To ensure accurate adjustments, use the following or equivalent test equipment.

Alternative test equipment must meet or exceed the intended minimum requirements specified in Table 19. If you substitute equipment, you may need to modify the procedures.

NOTE. Before making any adjustment, warm up the test equipment according to the manufacturer's recommendations.

Table 19: Adjustment test equipment

| Description | Minimum requirements | Example product |
|-----------------------------|--|---|
| Leveled Sine Wave Generator | 1 kHz to 250 MHz; variable amplitude from 5 mV to 4 V _{p-p} into 50 Ω | Wavetek 9100 Universal Calibration System with Oscilloscope Calibration Module (Option 250) |
| Time Mark Generator | Variable marker frequency from 1 ms to 10 ns; accuracy within 2 ppm | Fluke 5500A Multi-product Calibrator with Oscilloscope Calibration Option 5500A-SC |
| DC Calibration Generator | DC voltage levels from 100 mV to 10 V | |
| Digital Multimeter | 35 V, 4 A, ±0.1% Accuracy | Tektronix DMM914 Digital Multimeter |
| Termination (two required) | 50 Ω, female BNC input, male BNC output | Tektronix 011-0049-01 |
| Cable, Coaxial | 75 Ω, male-to-male BNC connectors, 36 inch length | Tektronix 012-1338-00 |
| Cable, Precision Coaxial | 50 Ω, male-to-male BNC connectors, 36 inch length | Tektronix 012-0482-00 |
| Coupler | Female-BNC-to-dual-male-BNC, dual-input | Tektronix 067-0525-02 |
| Probe | 10X probe | Tektronix P6109B |

Preparation for Adjustment

Perform the adjustment procedures on an as-needed basis. If an oscilloscope section fails a performance requirement, or if a section is replaced or repaired, adjust only that section. Adjusting individual sections of the oscilloscope rarely affects its overall performance.

In general, accurate adjustments require a stable, well-focused, low intensity display. Unless otherwise noted, adjust the INTENSITY, FOCUS, and TRIGGER LEVEL controls as needed to view the display.

In addition to the above, the following guidelines apply to all instrument adjustments:

- Perform the adjustments in a 20° to 30° C (68° to 86° F) ambient environment.
- Before making any adjustments, warm up the instrument for at least 20 minutes.
- Do not alter a setting unless a performance characteristic cannot be met at the current setting.
- Do not alter any setting without reading the entire adjustment procedure first.
- Read the *Safety Summary* at the beginning of this manual.

NOTE. *Altering the +12 V ADJ setting may require a complete readjustment of the instrument.*

Remove the Instrument Cover



You must remove the instrument cover to make internal adjustments.

WARNING. *To avoid electrical shock, always disconnect the power cord from its source before removing the instrument cover. After the adjustment procedures, replace the instrument cover before using the oscilloscope.*

To remove the cover, refer to Figure 12 while performing the following steps:

1. Remove the two cover screws on the instrument bottom.
2. Remove the four rear panel mounting screws.
3. Remove the rear panel.
4. Slide the cover off the rear of the instrument.

To reinstall the cover, perform steps 1 through 4 above in reverse order.

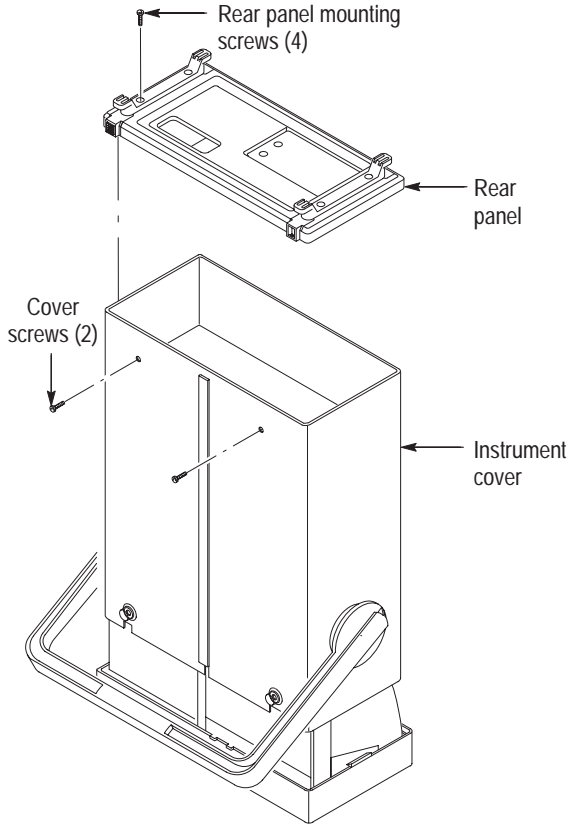

Figure 6: TAS 220 and TAS 250 instrument cover removal

Initial Settings Following the warm-up period, preset the oscilloscope to the settings listed below.

Table 20: Oscilloscope initial settings

| Control | Setting |
|--------------------------------|--------------------------|
| INTENSITY | Visible display |
| CURSOR ON/OFF | Off |
| VERTICAL | |
| CH 1 (CH 2) POSITION | Midrange |
| MODE | CH1 (CH2) |
| CH 1 (CH 2) VOLTS/DIV | 10 mV |
| CH 1 (CH 2) VOLTS/DIV VARIABLE | CAL |
| CH 1 (CH 2) GND | In |
| HORIZONTAL | |
| POSITION | Midrange |
| X10 MAG | Out |
| X-Y | Out |
| SWP UNCAL | Out |
| TRIGGER | |
| LEVEL | Midrange |
| MODE | AUTO |
| COUPLING | AC |
| SOURCE | CH 1 (CH 2) |
| SLOPE | Rising (push switch out) |

Power Supply Adjustments

To locate the adjustments and test points for the following procedures, refer to Figure 7. The Power and High Voltage board occupies the bottom-left side of the instrument below the CRT.

NOTE. The power supply section affects all other sections of the instrument. If you make repairs or adjustments that change the absolute value of any power supply voltage, you must complete the entire adjustment procedure.



WARNING. Use extreme caution when adjusting the power supply. The high voltages present can cause a fatal injury.

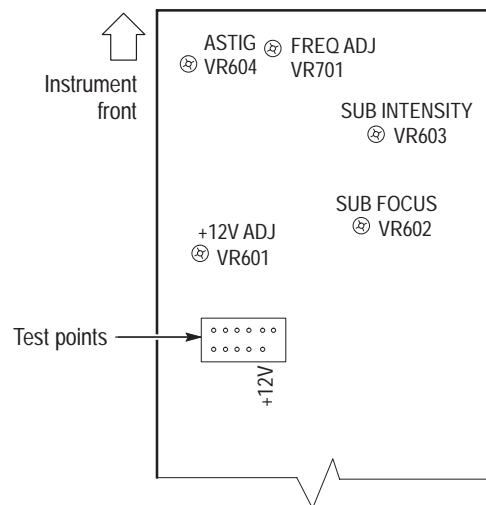

Figure 7: Power and High Voltage board (viewed from the instrument bottom)

+12 V Supply

Use the following procedure to adjust the +12 V power supply.

1. On the Power and High Voltage board, connect the voltmeter common lead to the oscilloscope chassis ground and the measurement lead to the +12 V test point. See Figure 7 for the test point location.
2. Verify that the voltmeter reads between +11.95 and +12.05 V. If the reading is within these limits, go to step 4.
3. Adjust VR601 for a voltmeter reading of +12 V. See Figure 7 for the adjustment location.

4. Verify that the voltage levels in Table 21 are within the specified limits. See Figure 7 for the test point locations.

Table 21: Power supply limits

| Power supply | Test point | Limits (volts) |
|----------------|------------|------------------|
| +12 | +12 | +11.95 to +12.05 |
| -12 | -12 | -11.80 to -12.20 |
| +5 | +5 | +4.75 to +5.25 |
| +185 (TAS 220) | +185 | +180 to +190 |
| +145 (TAS 250) | +145 | +140 to +150 |

NOTE. If a power supply measurement exceeds the limits specified in Table 21, discontinue the adjustment procedures. Contact a Tektronix service center for instrument repair.

5. Disconnect the voltmeter from the instrument.

Intensity

Use the following procedure to adjust the display intensity.

1. Set up the oscilloscope as follows:

| | |
|--------------------|------|
| HORIZONTAL SEC/DIV | 1 ms |
| TRIGGER HOLDOFF | NORM |
2. Rotate the front panel INTENSITY control to the fully counterclockwise position; then rotate the control clockwise to the 90° (nine o'clock) position.
3. Locate VR603 on the Power and High Voltage board (see Figure 7 for the adjustment location). Adjust VR603 until the trace is barely visible.
4. Rotate the INTENSITY control clockwise. Verify that the trace becomes brighter. Rotate the INTENSITY control fully counterclockwise; the trace should disappear.

Focus and Astigmatism

Use the following procedure to adjust the display focus and astigmatism.

1. Set the front panel FOCUS control to midrange; then adjust VR602 on the Power and High Voltage board to obtain the best focus. See Figure 7 for the adjustment location.
2. Set the front panel HORIZONTAL X-Y push switch to the in position.

3. Rotate the front panel HORIZONTAL POSITION control to move the dot to the display center. Rotate the INTENSITY control to give the dot a sharp edge.
4. Adjust VR604 on the Power and High Voltage board and the oscilloscope front panel FOCUS control until the dot becomes circular. See Figure 7 for the adjustment location.
5. Set the front panel HORIZONTAL X-Y push switch to the out position.
6. Repeat steps 1 through 5 for best performance.

Vertical Adjustments

To locate the adjustments for the following procedures, refer to Figures 8, 9, and 10. The Main board occupies the bottom-right side of the instrument.

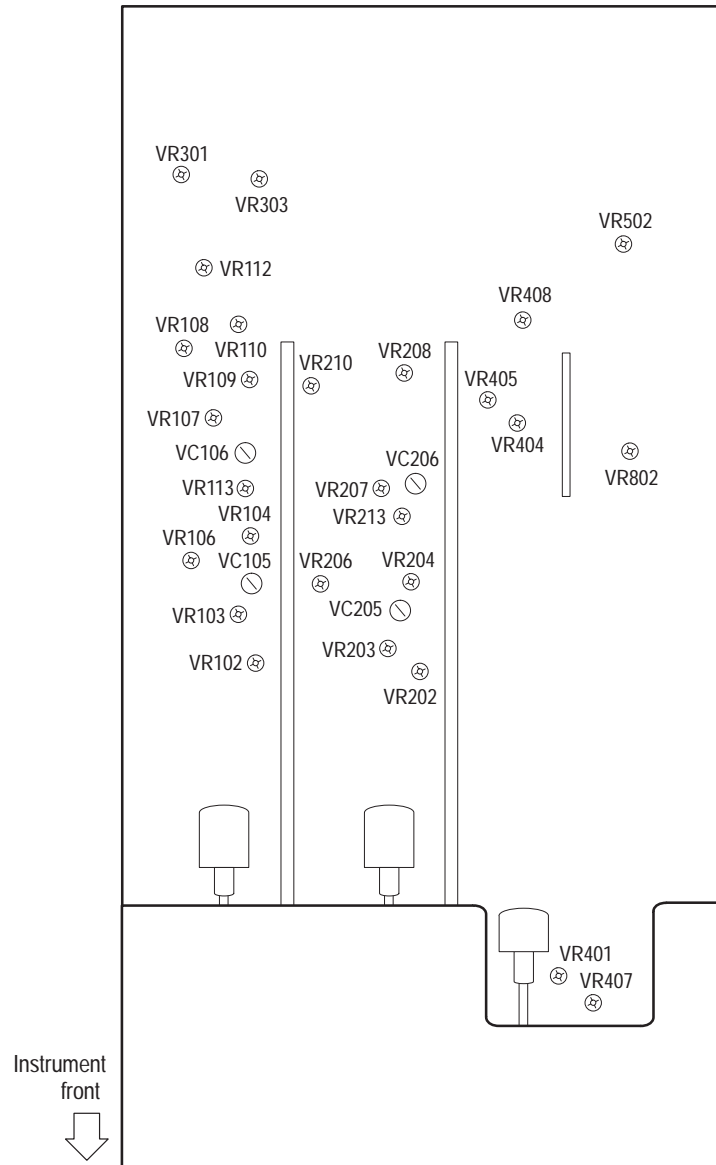

Figure 8: Main board (viewed from the instrument top)

DC Balance Use the following procedure to adjust the DC balance.

1. Set up the oscilloscope as follows:

| | |
|-------------------------------|-----------|
| VERTICAL MODE | CH1 (CH2) |
| CH 1 (CH 2) VERTICAL VARIABLE | CAL |
| CH 1 (CH 2) GND | In |

2. On the oscilloscope Main board, adjust VR101 (VR201) for a minimal trace shift when switching the front panel CH 1 (CH 2) VOLTS/DIV control between 5 mV and 10 mV. See Figure 10 for the adjustment locations.
3. Verify that the trace shift is less than ± 0.5 divisions for each CH 1 (CH 2) VOLTS/DIV step between 5 mV and 5 V.
4. On the Main board, adjust VR104 (VR204) for minimal trace shift when switching the CH 1 (CH 2) VOLTS/DIV control between 2 mV and 10 mV. See Figure 8 for the adjustment locations.
5. Verify that the trace shift is less than two divisions when switching the VOLTS/DIV control between 1 mV and 2 mV.
6. Set the VERTICAL MODE to CH2 and repeat steps 2 through 5 for CH 2.

Variable DC Balance Use the following procedure to adjust the variable DC balance.

1. Set up the oscilloscope as follows:

| | |
|-----------------------|-----------|
| VERTICAL MODE | CH1 (CH2) |
| CH 1 (CH 2) VOLTS/DIV | 10 mV |
| CH 1 (CH 2) VARIABLE | CAL |
| CH 1 (CH 2) GND | In |

2. On the Main board, adjust VR106 (VR206) for a minimal trace shift while rotating the front panel CH 1 (CH 2) VARIABLE control between the fully clockwise and the fully counterclockwise positions. See Figure 8 for the adjustment locations.
3. Set the VERTICAL MODE to CH2 and repeat step 2 for CH 2.

**Channel 2 Inverted
Balance and Position
Center**

Use the following procedure to adjust the channel 2 inverted balance and position center.

1. Set up the oscilloscope as follows:

| | |
|---------------|-----|
| VERTICAL MODE | CH2 |
| CH 2 GND | In |

2. Position the trace on the center horizontal graticule line using the CH 2 VERTICAL POSITION control.

3. Set the CH 2 VERTICAL INVERT push switch to the in position and note the new trace location.
4. On the Main board, adjust VR213 to position the trace half way back to the center horizontal graticule line. See Figure 8 for the adjustment location.
5. Set the channel 2 VERTICAL INVERT push switch to the out position.
6. If the trace shifts, adjust VR303 to return the trace to the center horizontal graticule line.
7. Repeat steps 3 through 6 to obtain a minimal trace shift ($<\pm 1$ division) when you toggle the CH 2 VERTICAL INVERT push switch in and out.

ADD Mode Balance

Use the following procedure to adjust the ADD mode balance.

1. Set up the oscilloscope as follows:

| | |
|-----------------------|-------|
| VERTICAL MODE | BOTH |
| CH 1 (CH 2) VOLTS/DIV | 10 mV |
| CH 1 (CH 2) VARIABLE | CAL |
| CH 1 (CH 2) GND | In |

2. Position both traces on the center horizontal graticule line using the CH 1 and CH 2 VERTICAL POSITION controls.
3. Set the VERTICAL MODE control to the ADD position.
4. On the Main board, adjust VR301 to position the trace on the center horizontal graticule line. See Figure 8 for the adjustment location.
5. Set the VERTICAL MODE switch to BOTH, CH2, and then CH1; verify that the trace shifts less than ± 1 division from the center of the display. If necessary, repeat steps 2 through 4 to obtain the best performance.

Vertical Gain

Use the following procedure to adjust the vertical gain.

1. Set up the oscilloscope as follows:

| | |
|-----------------------|-------|
| VERTICAL MODE | CH1 |
| CH 1 (CH 2) VOLTS/DIV | 10 mV |
| CH 1 (CH 2) VARIABLE | CAL |
| CH 1 (CH 2) AC-DC | DC |

2. Connect a 50 mV_{p-p} 50 kHz square wave to the CH 1 and CH 2 inputs with a dual input coupler.
3. On the Main board, adjust VR108 to obtain a waveform five divisions in amplitude. See Figure 8 for the adjustment location.

4. Set the CH 2 VERTICAL INVERT push switch to the in position.
5. Set the VERTICAL MODE control to the ADD position.
6. Position the trace to the center horizontal graticule.
7. Adjust VR208 to obtain a flat line. See Figure 8 for the adjustment location.

MAG Sensitivity

Use the following procedure to adjust the MAG Sensitivity.

1. Set up the oscilloscope as follows:

| | |
|-----------------------|-----------|
| VERTICAL MODE | CH1 (CH2) |
| CH 1 (CH 2) VOLTS/DIV | 2 mV |
| CH 1 (CH 2) VARIABLE | CAL |
| CH 2 INVERT | Out |
| CH 1 (CH 2) AC-DC | DC |

2. Connect a 10 mV_{p-p} 50 kHz square wave to the CH 1 (CH 2) input.
3. Adjust VR102 (VR202) to obtain a waveform five divisions in amplitude. See Figure 8 for the adjustment locations.
4. Set the VERTICAL MODE to CH2 and repeat steps 2 and 3 for CH 2.

High Frequency Compensation

Use the following procedure to adjust the high frequency compensation.

1. Set up the oscilloscope as follows:

| | |
|-----------------------|-------------|
| VERTICAL MODE | CH1 (CH2) |
| CH 1 (CH 2) VOLTS/DIV | 10 mV |
| CH 1 (CH 2) VARIABLE | CAL |
| CH 1, CH 2 AC-DC | AC |
| HORIZONTAL SEC/DIV | 0.2 μ s |

2. Connect a 20 MHz sine wave to the CH 1 (CH 2) input. Adjust the generator output to produce a waveform four divisions in amplitude on the display.
3. Adjust VC105 and VC106 (VC205, VC206) for maximum waveform amplitude. See Figure 8 for the adjustment locations.
4. Adjust VR103 (VR203) to obtain a maximum waveform amplitude. See Figure 8 for the adjustment locations.
5. Connect a 1 MHz square wave to the CH 1 (CH 2) input. Adjust the generator output to produce a waveform six divisions in amplitude on the display.
6. Adjust VR302 and VC301 to optimize the waveform flatness. See Figure 9 for the adjustment location.

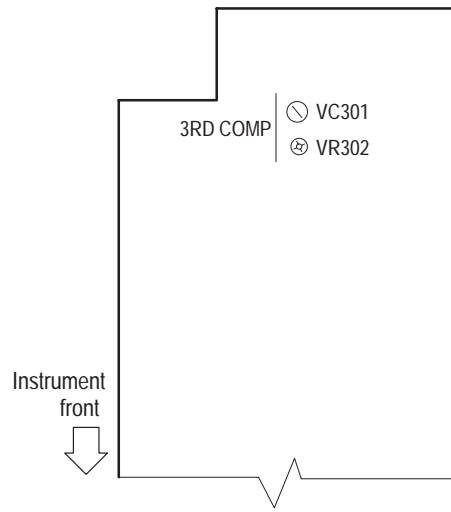

Figure 9: Power and High Voltage board (viewed from the instrument bottom)

7. Adjust VR107 (VR207) to optimize the waveform flatness. See Figure 8 for the adjustment locations.
8. Readjust VR103 (VR203) to reduce peak aberrations to less than 0.24 divisions while maintaining peak-to-peak aberrations less than 0.36 divisions. See Figure 8 for the adjustment locations.
9. Connect a 50 kHz sine wave to the CH 1 (CH 2) input. Adjust the generator output to produce a waveform six divisions in amplitude on the display.
10. Increase the frequency to 20 MHz for the TAS 220 or 50 MHz for the TAS 250. Verify that the waveform amplitude exceeds 4.2 divisions at these frequencies.
11. Set the oscilloscope CH 1 (CH 2) VOLTS/DIV to 1 mV and the sine wave generator to 50 kHz. Adjust the generator output to produce a waveform eight divisions in amplitude on the display.
12. Increase the frequency to 10 MHz for the TAS 220 or 15 MHz for the TAS 250. Verify that the waveform amplitude exceeds 5.6 divisions at these frequencies.
13. If steps 10 or 12 fail the specified criteria, repeat steps 7, 8, and 9.
14. Set the VERTICAL MODE to CH2 and repeat steps 2 through 13 for CH 2.

Attenuator Compensation

Use the following procedure to adjust the vertical input attenuator compensation.

1. Set up the oscilloscope as follows:

| | |
|-----------------------|-------|
| VERTICAL MODE | BOTH |
| CH 1 (CH 2) VOLTS/DIV | 0.1 V |
| CH 1 (CH 2) VARIABLE | CAL |
| CH 1 (CH 2) AC-DC | DC |

2. Connect a 1 kHz square wave to the CH 1 (CH 2) input. Adjust the generator output to produce a waveform five divisions in amplitude on the display.
3. Adjust VC102 (VC202) to obtain an optimum waveform symmetry with minimal overshoot. See Figure 10 for the adjustment locations.

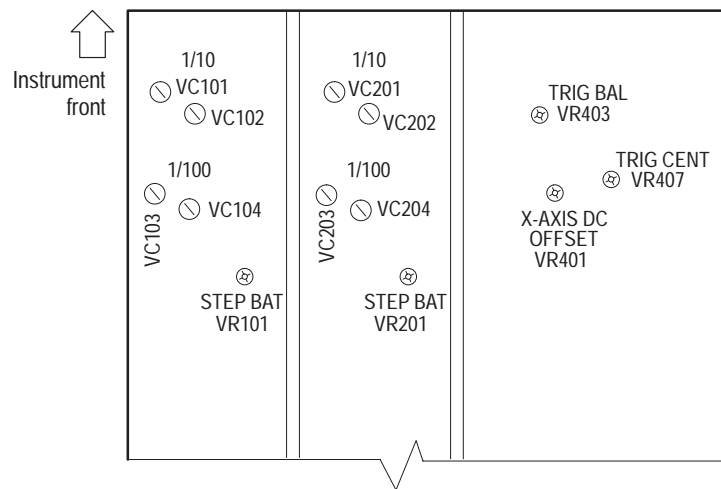

Figure 10: Main board (viewed from the instrument bottom)

4. Set the CH 1 (CH 2) VOLTS/DIV control to 1 V.
5. Readjust the generator output to produce a waveform five divisions in amplitude. Adjust VC104 (VC204) to obtain an optimum waveform symmetry with minimal overshoot. See Figure 10 for the adjustment locations.
6. Disconnect the square wave generator from the instrument.
7. Connect a 10X probe to the CH1 (CH 2) input.
8. Set the CH 1 (CH 2) VOLTS/DIV control to 10 mV/division.

9. Connect the probe to the square wave generator and confirm that the output is a 1 kHz square wave. Adjust the generator output to produce a waveform five divisions in amplitude on the display. Adjust the probe compensation to flatten and optimize the waveform.
10. Set the CH 1 (CH 2) VOLTS/DIV control to 0.1 V.
11. Readjust the generator output to produce a waveform five divisions in amplitude.
12. Adjust VC101 (VC201) to flatten the waveform. See Figure 10 for the adjustment locations.
13. Set the CH 1 (CH 2) VOLTS/DIV control to 1 V.
14. Readjust the generator output to produce a waveform five divisions in amplitude.
15. Adjust VC103 (VC203) to flatten the waveform. See Figure 10 for the adjustment locations.
16. For each setting of the CH 1 (CH 2) VOLTS/DIV control, adjust the generator output to produce a waveform five divisions in amplitude. Evaluate the waveform for optimum symmetry and flatness at each setting.
17. Set the VERTICAL MODE to CH2 and repeat steps 2 through 16 for CH 2.

Channel 1 Output DC Offset

Use the following procedure to adjust the channel 1 output DC offset.

1. Set up the oscilloscope as follows:

| | |
|-----------------------|-------|
| VERTICAL MODE | BOTH |
| CH 1 (CH 2) VOLTS/DIV | 10 mV |
| CH 1 (CH 2) VARIABLE | CAL |
| CH 1 (CH 2) GND | In |
| TRIGGER SOURCE | CH 1 |
2. Position the CH 1 and CH 2 traces to the center horizontal graticule line with the VERTICAL POSITION controls.
3. Connect the rear panel CH 1 OUTPUT to the front panel CH 2 input with a 50 Ω coaxial cable.
4. Set the CH 2 GND push switch to the out position.
5. On the Main board, adjust VR112 to position the CH 2 trace to the center horizontal graticule line. See Figure 8 for the adjustment location.

Horizontal Adjustments

To locate the adjustments for the following procedures, refer to Figures 8 and 10. The Main board occupies the bottom-right side of the instrument.

X10 MAG Registration

Use the following procedure to adjust the X10 MAG registration.

1. Set up the oscilloscope as follows:

| | |
|------------------------|----------|
| VERTICAL MODE | CH1 |
| CH 1 VERTICAL POSITION | Midrange |
| HORIZONTAL SEC/DIV | 1 ms |

2. Rotate the HORIZONTAL POSITION control to move the left edge of the trace to the display center (center vertical graticule line).
3. Set the HORIZONTAL X10 MAG push switch to the in position. Verify that the trace is located within ± 1 division of the display vertical center. If the trace does not line up, use the HORIZONTAL POSITION control to reposition the trace to the display center.
4. Set the HORIZONTAL X10 MAG push switch to the out position. Adjust VR502 to position the trace edge to the display vertical center. See Figure 8 for the adjustment location.
5. Repeat steps 3 and 4 until the trace edge remains within ± 1 division of the display center when pressing the HORIZONTAL X10 MAG push switch in and out.

Horizontal Position

Use the following procedure to adjust the horizontal position.

1. Set up the oscilloscope as follows:

| | |
|------------------------|----------|
| VERTICAL MODE | CH1 |
| CH 1 VERTICAL POSITION | Midrange |
| HORIZONTAL SEC/DIV | 1 ms |

2. Center the HORIZONTAL POSITION control.
3. Adjust VR408 to align the left edge of the trace to the left-most graticule of the display. See Figure 8 for the adjustment location.

1 ms Timing

Use the following procedure to adjust the 1 ms timing.

1. Set up the oscilloscope as follows:

| | |
|------------------------|----------|
| VERTICAL MODE | CH1 |
| CH 1 VERTICAL POSITION | Midrange |

| | |
|--------------------|------|
| HORIZONTAL SEC/DIV | 1 ms |
| SWEEP UNCAL | Out |

2. Connect the time mark generator to the CH 1 input with a 50 Ω coaxial cable and 50 Ω termination.
3. Set up the generator to produce a 1 ms output.
4. Adjust the generator output to produce a waveform two divisions in amplitude on the display.
5. Adjust VR405 for a one marker per division display over the center eight divisions. See Figure 8 for the adjustment location.

1 μ s and .1 μ s Timing

Use the following procedure to adjust the 1 μ s and .1 μ s timing.

1. Set up the oscilloscope as follows:

| | |
|------------------------|-----------|
| VERTICAL MODE | CH1 |
| CH 1 VERTICAL POSITION | Midrange |
| HORIZONTAL SEC/DIV | 1 μ s |
| HORIZONTAL SWP UNCAL | Out |

2. Connect the time mark generator to the CH 1 input with a 50 Ω coaxial cable and 50 Ω termination.
3. Set up the generator to produce a 1 μ s output.
4. Adjust the generator output to produce a waveform one division in amplitude on the display.
5. Adjust VR404 for a one marker per division display. See Figure 8 for the adjustment location.
6. Set the generator to produce a .1 μ s output.
7. Set the HORIZONTAL SEC/DIV control to .1 μ s.
8. Adjust VR802 for a one marker per division display. See Figure 8 for the adjustment location.

X-Gain Accuracy

Use the following procedure to adjust the X-gain accuracy.

1. Set up the oscilloscope as follows:

| | |
|----------------|-------|
| VERTICAL MODE | X-Y |
| CH 1 VOLTS/DIV | 10 mV |
| CH 1 VARIABLE | CAL |
| HORIZONTAL X-Y | In |

| | |
|------------------|-----|
| TRIGGER COUPLING | AC |
| TRIGGER SOURCE | X-Y |

2. Use a 50 Ω coaxial cable to connect the square wave generator to the CH 1 input. Set up the generator for a 1 kHz 50 mV output.
3. Adjust VR109 for exactly five divisions of horizontal deflection on the display. See Figure 8 for the adjustment location.

X-Axis Offset Use the following procedure to adjust the X-axis DC offset.

1. Set up the oscilloscope as follows:

| | |
|------------------------|----------|
| CH 1 VERTICAL POSITION | Midrange |
| VERTICAL MODE | CH1 |
| CH 1 VOLTS/DIV | 50 mV |
| CH 1 GND | In |
| HORIZONTAL SEC/DIV | 1 ms |
| HORIZONTAL X-Y | Out |
| TRIGGER MODE | AUTO |

2. Position the trace vertically to the horizontal center graticule line.
3. Position the left edge of the trace horizontally to the first vertical graticule line (extreme left).
4. Set the HORIZONTAL X-Y push switch to the in position.
5. Adjust VR401 to position the spot to the center vertical graticule line. See Figure 10 for the adjustment location.

Trigger Adjustments

To locate the adjustments for the following procedures, refer to Figures 8 and 10. The Main board occupies the bottom-right side of the instrument.

Trigger DC Offset

Use the following procedure to adjust the trigger DC offset.

1. Set up the oscilloscope as follows:

| | |
|-------------------------------|-------------|
| CH 1 (CH 2) VERTICAL POSITION | Midrange |
| VERTICAL MODE | CH1 (CH2) |
| CH 1 (CH 2) VOLTS/DIV | 10 mV |
| CH 1 (CH 2) VARIABLE | CAL |
| CH 1 (CH 2) AC-DC | AC |
| HORIZONTAL SEC/DIV | 1 ms |
| TRIGGER COUPLING | AC |
| TRIGGER SOURCE | CH 1 (CH 2) |

2. Connect a 50 kHz sine wave to the CH 1 (CH 2) input. Adjust the generator output to produce a waveform eight divisions in amplitude on the display.
3. Rotate the TRIGGER LEVEL control to set the trigger point at the center of the signal swing.
4. Alternate the TRIGGER COUPLING control between the AC and DC positions. Adjust VR110 (VR210) until the oscilloscope triggers at the same amplitude for both switch positions. See Figure 8 for the adjustment location.
5. Set the VERTICAL MODE and TRIGGER SOURCE to CH2 and repeat steps 2 through 4 for channel 2.

Trigger Slope Balance

Use the following procedure to adjust the trigger slope balance.

1. Set up the oscilloscope as follows:

| | |
|--------------------|------|
| VERTICAL MODE | CH1 |
| CH 1 AC-DC | AC |
| CH 1 GND | In |
| HORIZONTAL SEC/DIV | 1 ms |

| | |
|--------------------|--------------------------|
| TRIGGER SET TO 50% | In |
| TRIGGER SLOPE | Falling (push switch in) |

2. Use a DMM to measure the collector voltage of Q414. Adjust VR403 for a reading of $1.40\text{ V} \pm 0.02\text{ V}$. See Figure 10 for the adjustment location.
3. Set the CH 1 GND push switch to the out position.
4. Connect a 50 kHz sine wave to the CH 1 input. Adjust the generator output to produce a waveform four divisions in amplitude on the display.
5. Alternate the TRIGGER SLOPE push switch between the rising (in) and falling (out) slope settings. Adjust VR403 for a 0.4 division downward vertical shift at the beginning of the sweep. See Figure 10 for the adjustment location.

Trigger Center

Use the following procedure to adjust the trigger center.

1. Set up the oscilloscope as follows:

| | |
|--------------------|------|
| HORIZONTAL SEC/DIV | 1 ms |
| TRIGGER SOURCE | CH 1 |
| TRIGGER SET TO 50% | In |
| CH 1 AC-DC | AC |

2. Connect a 50 kHz sine wave to the CH 1 input. Adjust the generator output to produce a waveform eight divisions in amplitude on the display.
3. Verify that the trigger point is within ± 1.5 divisions of the signal swing center.
4. Readjust the oscilloscope controls as follows:

| | |
|--------------------|--------|
| TRIGGER SET TO 50% | Out |
| TRIGGER LEVEL | Midway |

5. Adjust VR407 to position the trigger points equidistant from the center horizontal graticule line. See Figure 10 for the adjustment location.

Probe Compensation

To locate the adjustment for the following procedure, refer to Figure 11. The Power and High Voltage board occupies the bottom-left side of the instrument below the CRT.

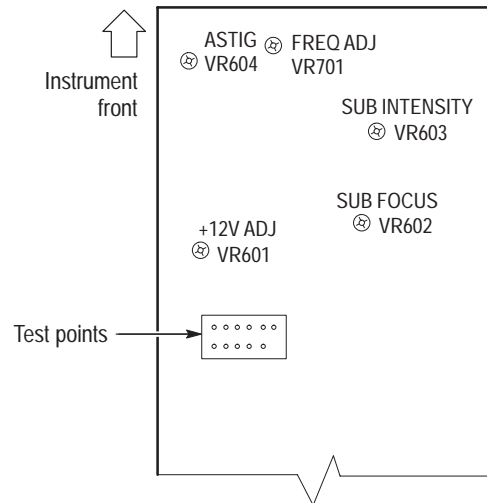

Figure 11: Power and High Voltage board (viewed from the instrument bottom)

1. Set up the oscilloscope as follows:

| | |
|--------------------|--------|
| VERTICAL MODE | CH1 |
| CH 1 VOLTS/DIV | 0.5 V |
| CH 1 AC-DC | DC |
| HORIZONTAL SEC/DIV | 0.2 ms |
| TRIGGER COUPLING | DC |
| TRIGGER SOURCE | CH 1 |

2. Connect the probe to the CH 1 input connector
3. Touch the probe tip to the PROBE COMP tab on the left side of the front panel.
4. Adjust the probe (compensation) for a flat-topped square wave on the display.
5. Adjust VR701 on the Power and High Voltage board until one cycle spans five divisions. See Figure 11 for the adjustment location.
6. Verify that the display amplitude is $2 V_{p-p} \pm 2\%$ and the duty-cycle ratio is approximately 1 to 1.

Cursors and Readout Adjustments

To locate the adjustments for the following procedures, refer to Figure 13. The Control and I/O board occupies the top left-hand corner of the instrument.

Cursor Accuracy Use the following procedure to adjust the cursor accuracy.

1. Simultaneously press the front panel PROBE X1/X10 and the $\Delta V/\Delta T$ 1/ ΔT push switches to display the cursor calibration square.

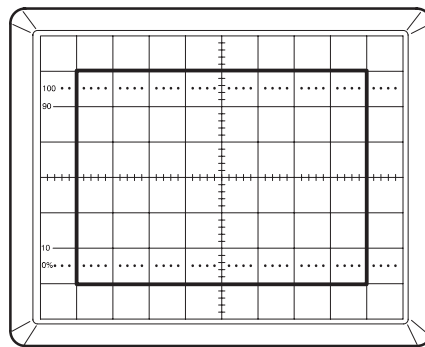

Figure 12: Cursor calibration display

2. On the Control and I/O board, adjust the following potentiometers to position the alignment square as shown in Figure 12. See Figure 13 for the adjustment locations.

| | |
|-------------|-------|
| X-Gain: | VRA01 |
| X-Position: | VRA02 |
| Y-Gain: | VRA03 |
| Y-Position: | VRA04 |

3. Simultaneously press the PROBE X1/X10 and the $\Delta V/\Delta T$ 1/ ΔT push switches again to exit the adjustment mode.

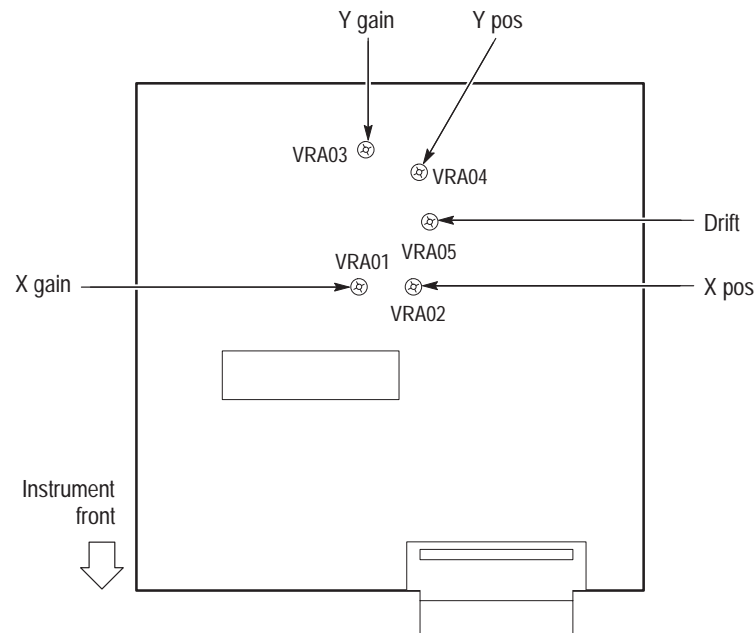

Figure 13: Control and I/O board (viewed from the instrument top)

Drift Use the following procedure to minimize the readout drift.

1. If the display readouts are not visible, simultaneously press the front panel PROBE X1/X10 and the CURSOR ON/OFF push switches.
2. While toggling the VERTICAL MODE switch between BOTH and ADD positions, adjust VRA05 on the Control and I/O board to minimize the character drift.
3. Simultaneously press the PROBE X1/X10 and the $\Delta V/\Delta T$ 1/ ΔT push switches to turn off the display readouts, if desired.